

Offshore Cylinder Packs

Air Liquide's exclusive offshore compressed gas packaging solution



Benefits and Features

- Proof load tested in compliance with DNV 2.7-1 standards for offshore systems
- Unique PE-engineered 4-point lift system and frame design
- Angled-pad eyes meet or exceed industry standards for easier, safer lifting
- Features dual-outlet pre-piped manifold with 16 50-liter cylinders for expanded capacity that eliminates frequent cylinder exchange
- Certified slings conform to US cargo control specifications
- All packs have Residual Pressure Valves (RPVs) for added safety
- Protective top grate prevents damage to valve and manifold
- Palletized and forklift-friendly for easy mobility
- Visible data plate easily identifies pack-specific information:
 - Payload
 - Test date
 - Pack ID number
 - Inspection dates
 - NDT information
 - Maximum gross weight
- Reduce purchasing costs, simplify records keeping and minimize on-site cylinder inventory with cloud computing via SHOP@airliquide cylinder management system

Offshore Cylinder Packs

Your complete offshore package solution

Description	Cylinder Size	Part Number	Unit of Measure	psig	Volume* (CF)	UN Number	Hazard Class
Argon 16-Pack	50L	390-U50/16-PEC	PK	2200	4896	1006	2.2
Argon/Carbon Dioxide (75%/25%) 16-Pack	50L	422-U50/16-PEC	PK	2200	4736	1956	2.2
Helium 16-Pack	50L	620-U50/16-PEC	PK	2200	4656	1046	2.2
Nitrogen 16-Pack	50L	760-U50/16-PEC	PK	2200	4464	1066	2.2
Oxygen 16-Pack	50L	900-U50/16-PEC	PK	2200	4912	1072	2.2

* Approximate

Offshore Cylinder Pack Details

- **Dimensions:**
3'4" (w) x 3'4" (d) x 6'11" (h)
- **Empty tare weight:** 2,900 lbs.
- **Working load limit/payload:** 800 lbs.
- **Maximum gross weight:** 3,700 lbs.
- **Proof load tested to:** 10,000 lbs.

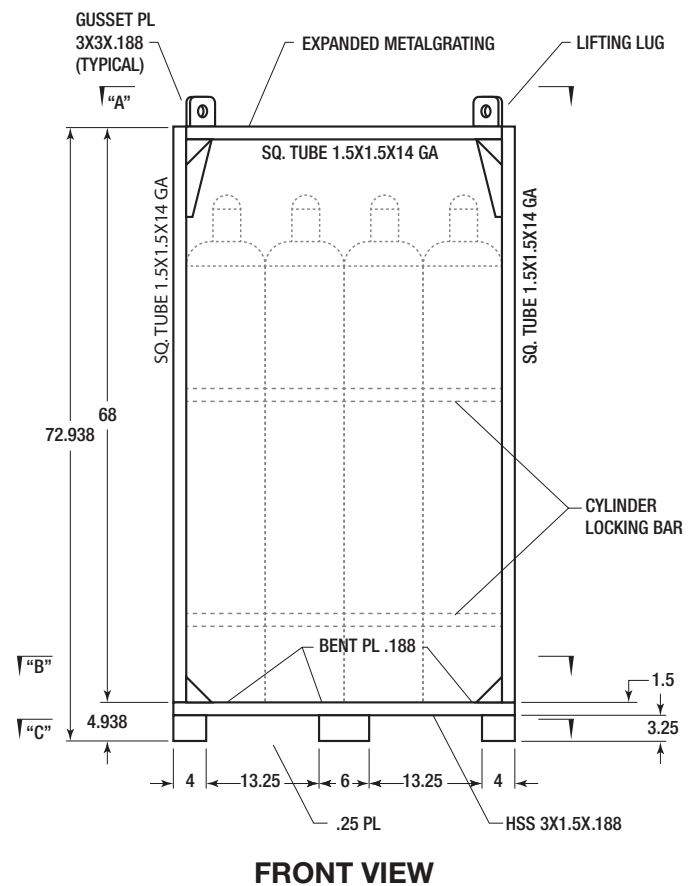
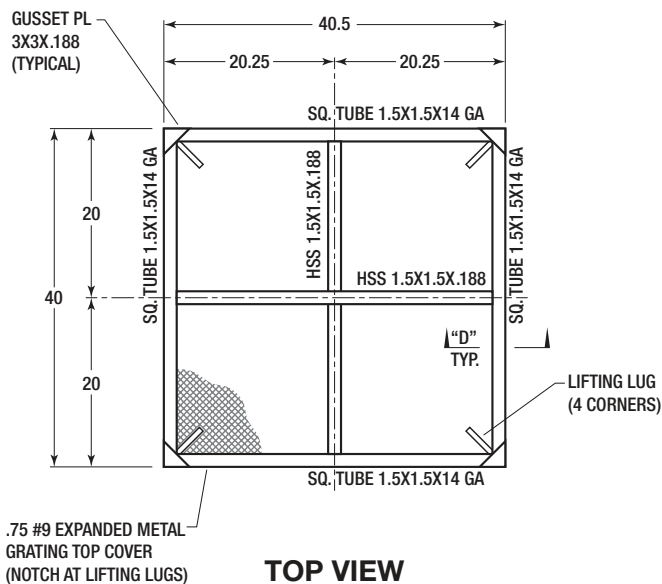

Founded in 1902, Air Liquide is the world leader in gases for industry, health and the environment, providing innovative solutions for the manufacture of everyday products and for the protection of life.

NOTE: This brochure is intended for general information purposes only and is not intended as a representation or warranty of any kind, or as a statement of any terms or condition of sale. The information herein is believed to be correct, but is not warranted for correctness or completeness or for applicability to any particular customer or situation.

MOLECULES THAT MATTER is a trademark of the Air Liquide Group. ©2012 Air Liquide America Specialty Gases LLC



Air Liquide America Specialty Gases LLC
6141 Easton Road
Box 310
Plumsteadville, PA 18949

Phone: 800.217.2688
Fax: 215.766.2476
Email: solutions.center@airliquide.com
www.ALspecialtygases.com

All rights reserved 01/12-TGI 1M